



# CEDREM

**FULLY COMPLIANT  
WITH NATO AEP-55 (C)  
STANAG STANDARD  
(MAS AND SWAS DETECTION).**

**KINETIC VULNERABILITY ASSESSMENT  
SOFTWARE MEASURING ANY GEOMETRY  
PERCENTAGE OF PROTECTED AREA.**

**— ASSESS EVERYTHING**

ANALYSE ANY KIND OF STRUCTURE  
BASED ON ITS CAD FILE.

**— CONSIDER EVERY THREAT**

CALCULATE THE VULNERABILITY OF ANY STRUCTURE  
AGAINST ANY LEVEL OF THREAT.

**— SAVE MONEY**

FAST AND RELIABLE RESULTS. PREVENTING LONG,  
EXPENSIVE AND UNCLEAR EXPERIMENTS.

**— LEAD PROTECTION**

AFTER SCREENING EVERY CORNER OF THE GEOMETRY  
KVA HIGHLIGHTS ALL WEAKNESSES — LEADING TO  
IMPROVED PROTECTION

The CEDREM is an award winning French engineering service provider specialized in composite structures and materials subjected to dynamic phenomena such as crash, ballistic impact, explosion, blast and more. CEDREM's team of research engineers offers expertise in all aspects of physics, electro-magnetism, materials, mechanics, fluid mechanics, explosion, ballistics, and numerical simulation.

CEDREM skills are numerical simulation of dynamic behavior, development of predictive numerical tools, research on composite materials, material law calibration, material characterization (static and dynamic), Design Of Experiment (DOE) and solution optimization.

Specialized in security and defense, and relying on a 15 years experience, CEDREM has conceived several software and plugins that have become industry references. **KTex Family** and **HUByX** are now included in **ALTAIR HyperWorks™** suite.

**KVA** is CEDREM latest release and this standalone offers the following:

- Fast and friendly user interface.
- Very light CAD abilities required.
- Full study in less than 8 weeks.
- Simulation of shots from any direction (0° to 360° in azimuth and elevation).
- Compliant with **NATO AEP-55 (C) STANAG** standard (MAs and SWAs detection).
- Calculation of protected area percentage based on CAD file.
- In-house protection database available.
- Bespoke protection integration solutions are available.

# KVA SOFTWARE BY CEDREM

## ASSESS EVERYTHING !

### KVA SOFTWARE

**SOFTWARE LICENSE OR CONSULTANCY STUDIES**

|                   |                         |
|-------------------|-------------------------|
| Centre            | C E D R E M             |
| Expertise         | E c o p a r c           |
| Dynamique         | 41210 - Neung/Beuvron   |
| Rapide            | F r a n c e             |
| Explosion         | kontakt@cedrem.fr       |
| Multiphysique     | Tel: +33(0)2 54 946 271 |
| c e d r e m . f r |                         |

# ARMY TROOPS



PROTECTED AND UNPROTECTED AREAS

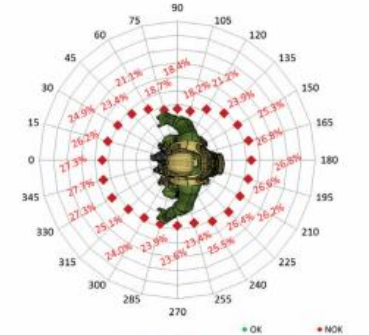

# ARMORED VEHICLES

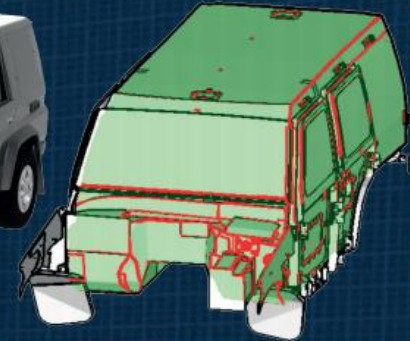

PROTECTED AND UNPROTECTED AREAS

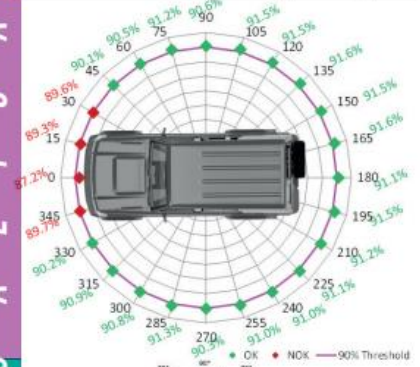

# AERONAUTICS



NEW DESIGN OF ARMORED SEATS



PROTECTED AND UNPROTECTED AREAS

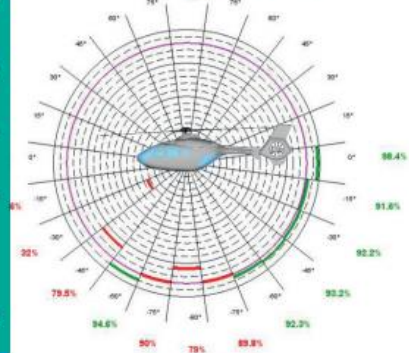

# NAVAL

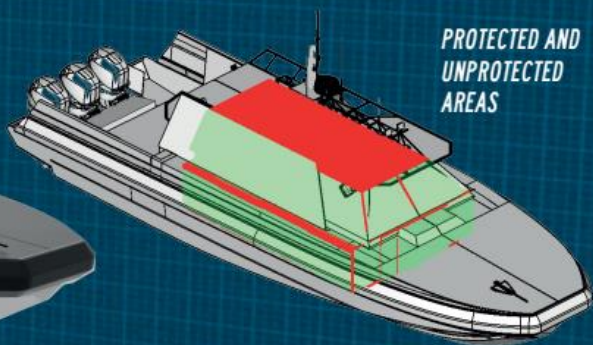

PROTECTED AND UNPROTECTED AREAS

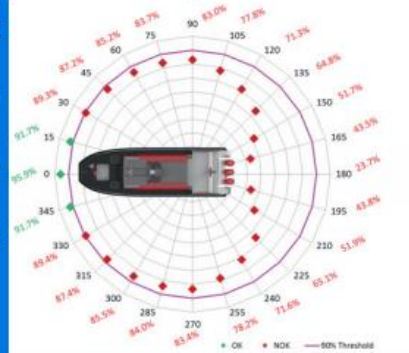

POLARIZATION